

## PRODUCT SPECIFICATION FOR INFORMATION

- Product Name : CERAMIC BANDPASS FILTER
- Part No : MBP-8R4-1812.5BP100M

PRELIMINARY SPECIFICATION

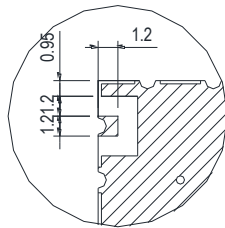
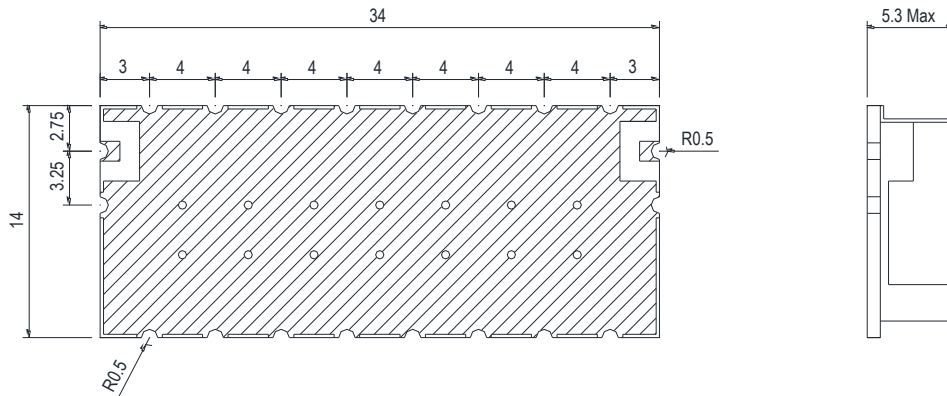

A-A

Unit : mm  
Tolerance : +/- 0.3

1. Center Frequency : 1812.5MHz
2. 3dB Bandwidth : 100MHz (1762.5 ~ 1862MHz)
3. Insertion Loss in BW : 3.0dB Max.
4. Ripple in BW :  $\pm 0.25$ dB Max.
5. Rejection : 60dB Min. @ 1 MHz to 1650MHz.  
60dB Min. @ 2000MHz to 4000MHz.
6. Input Power : 1.0W Max.
7. Impedance : 50 $\Omega$
8. Operating Temperature : -40 $^{\circ}$ C ~ +85 $^{\circ}$ C
9. Size : 34 X 14 X 5mm

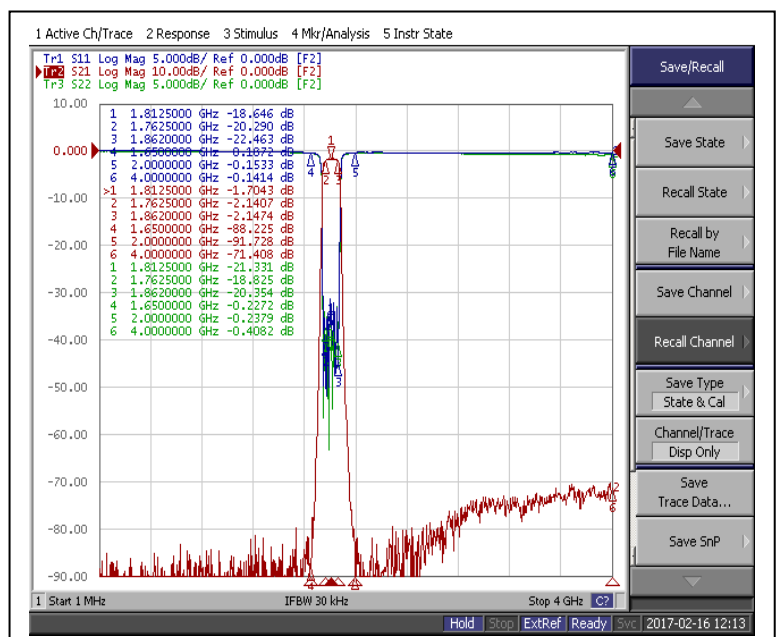

[ PLOT DATA ]

■ Land Pattern

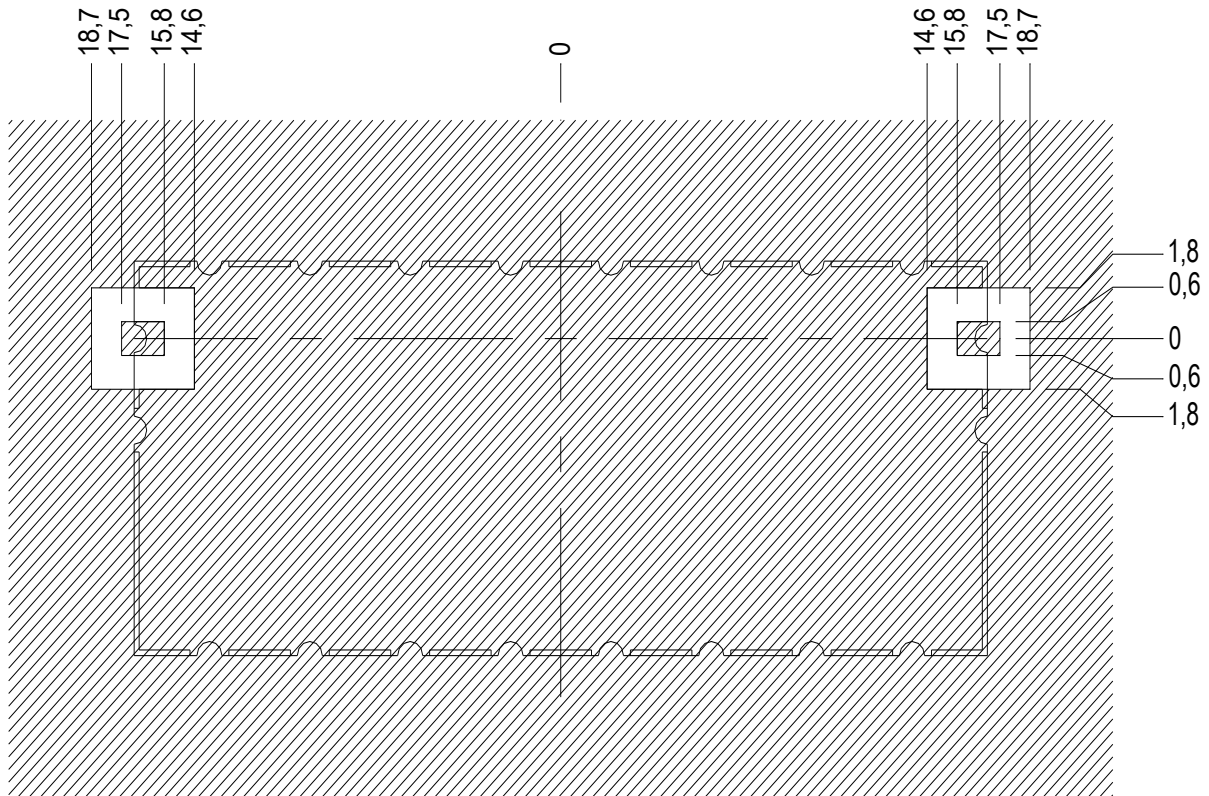

■ Solder Resistor

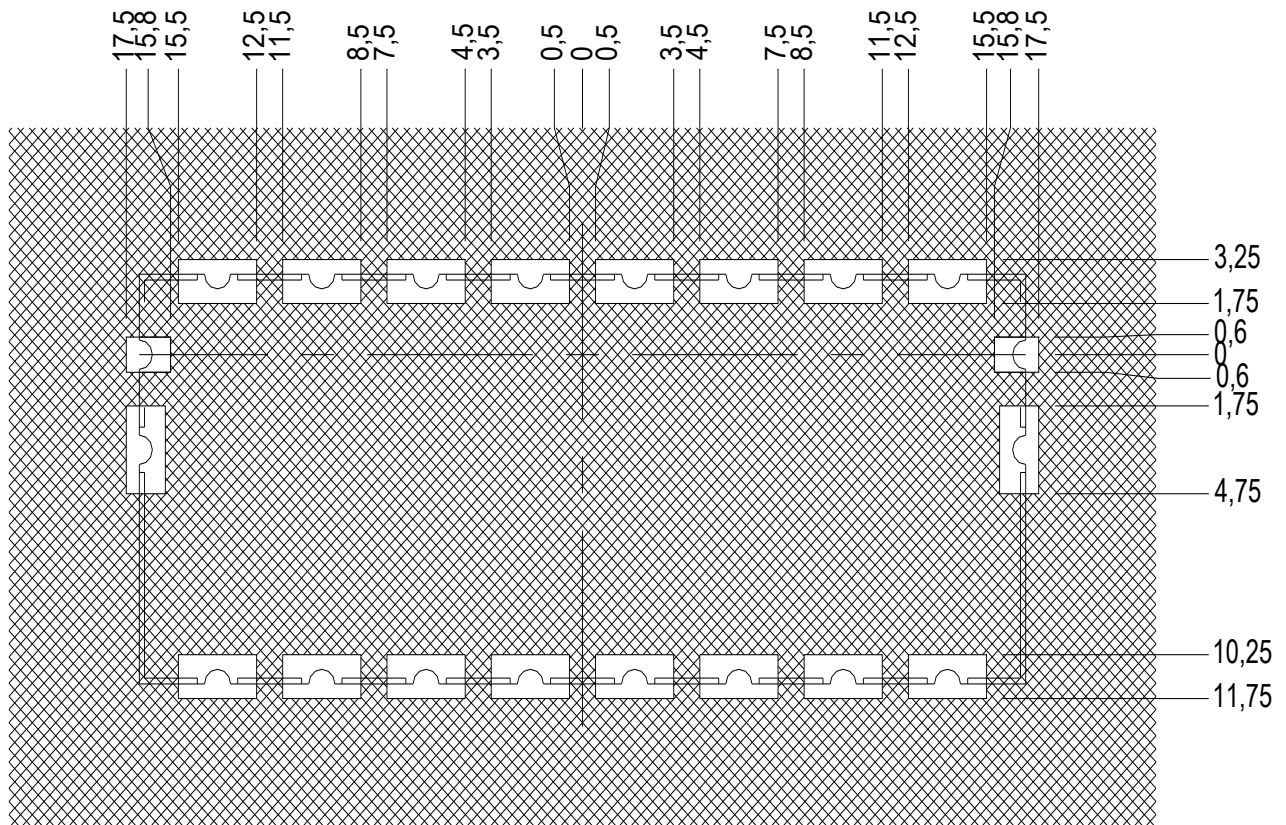

## ■ Soldering Time Profile

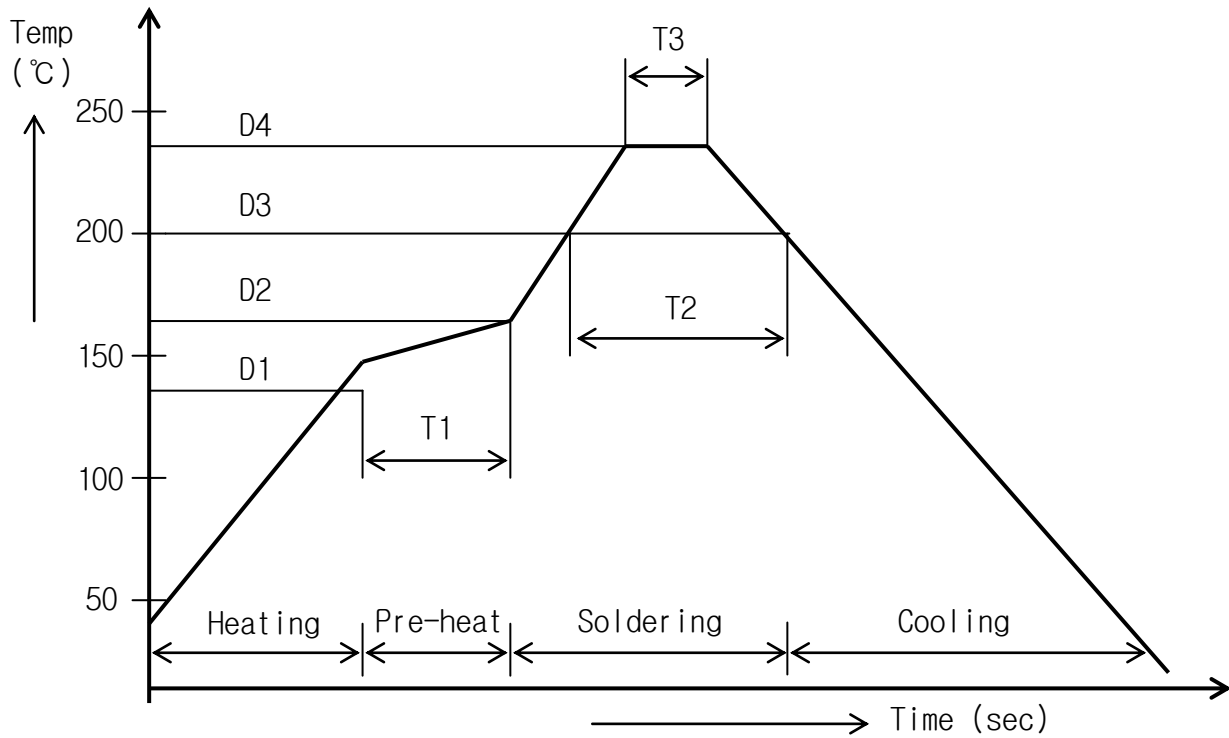

No	ITEM	TEMPERATURE	TIME(SEC)
1	PRE-HEAT	D1 : 140 ~ D2 : 160	T1 : 60±20
2	SOLDERING	D3 : 200	T2 : 20 ~ 30
3	TEMPERATURE	D4 : 230±10	T3 : 7 MAX

### 1) Soldering Iron Condition

- (1) Temperature : 230°C max
- (2) Duration : 4 sec max (1 part)
- (3) Capacity : 3W max