

PRODUCT SPECIFICATION FOR INFORMATION

- Customer : Equipements Scientifiques
- Product Name : CERAMIC BANDPASS FILTER
- Part No : MBP-8R4-2600BP1100M

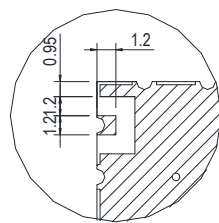
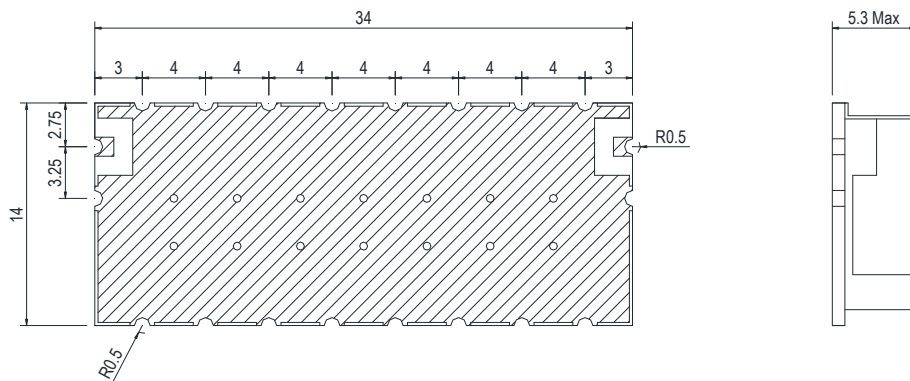

A-A

Unit : mm
Tolerance : +/- 0.3

- Center Frequency : 2600MHz
- 3dB Bandwidth : 1100MHz (2050 ~ 3150MHz)
- Insertion Loss(IL) : 3dB Max.
- Ripple : 1.0dB (max).
- Rejection : 60dB Min. @ 1 MHz to 1750MHz.
60dB Min. @ 3500MHz to 5000MHz.
- Return Loss : 12dB Min.
- Input Power : 1.0W Max.
- Impedance : 50Ω
- Operating Temperature : -40°C ~ +85°C
- Size : 34 X 14 X 5 mm

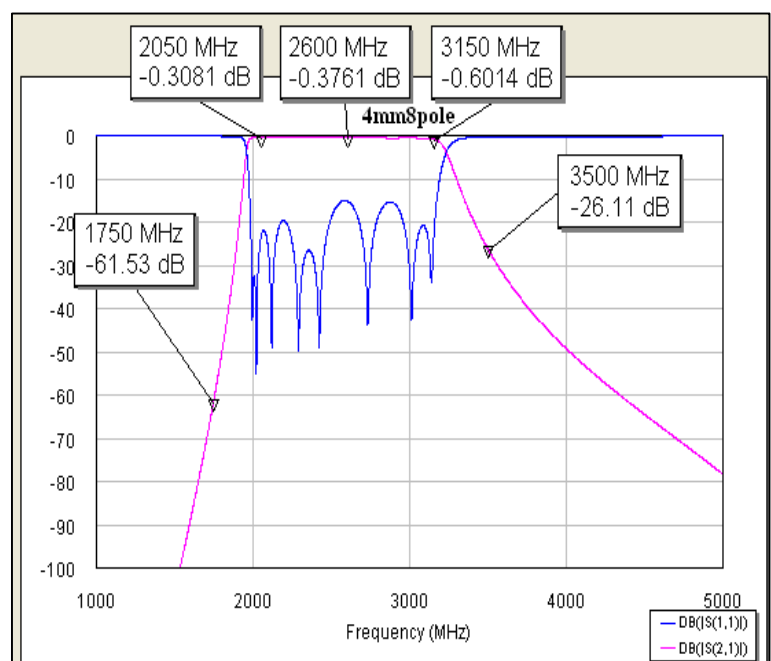

[PLOT DATA]