

PRODUCT SPECIFICATION FOR INFORMATION

- Customer : Equipements Scientifiques
- Product Name : CERAMIC BANDPASS FILTER
- Part No : MBP-8R4-5500BP1200M

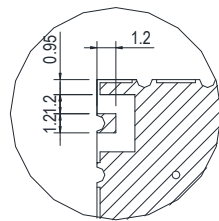
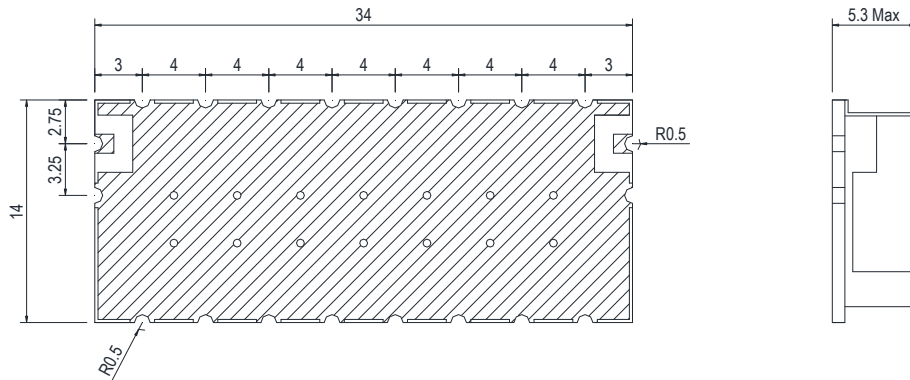

A-A

Unit : mm
Tolerance : +/- 0.3

1. Center Frequency : 5500MHz
2. 3dB Bandwidth : 1200MHz (4900 ~ 6100MHz)
3. Insertion Loss(IL) : 1.5dB Max.
4. Ripple : 1.0dB (max).
5. Rejection : 60dB Min. @ 10 MHz to 3050MHz.
50dB Min. @ 7000MHz to 8500MHz.
6. Input Power : 1.0W Max.
7. Impedance : 50Ω
8. Operating Temperature : -40℃ ~ +85℃
9. Size : 34 X 14 X 5 mm

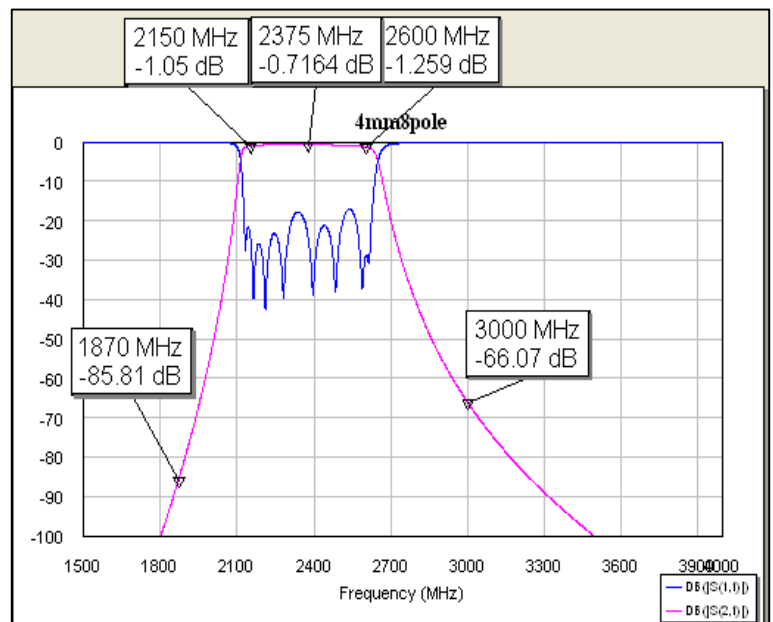

[PLOT DATA]