

**GaAs Monolithic Microwave Integrated Circuit
X-Band Directional Coupler**

Features:

- Pass Band : 8~12GHz
- Insertion Loss : 0.7 dB Max.
- Size : 2.26x0.96x0.1mm



Absolute Maximum Ratings

- Max. Input Power : +33 dBm
- Storage Temperature : -65 ~ +150Deg.C
- Operating Temperature : -55 ~ +125Deg.C

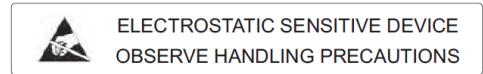

Electrical Specifications (TA=+25Deg.C, 50Ω system)

Parameter	Min.Value	Typical Value	Max.Value	Unit
Frequency Range	8-12			GHz
Insertion Loss	-	0.43	0.70	dB
Coupling value	22.77	23.16	24.35	dB
Isolation	25.17	26.60	-	dB
Input Return Loss	15.36	18.97	-	dB

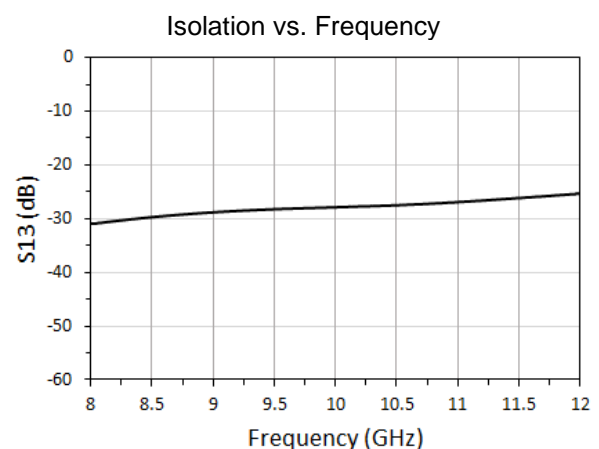
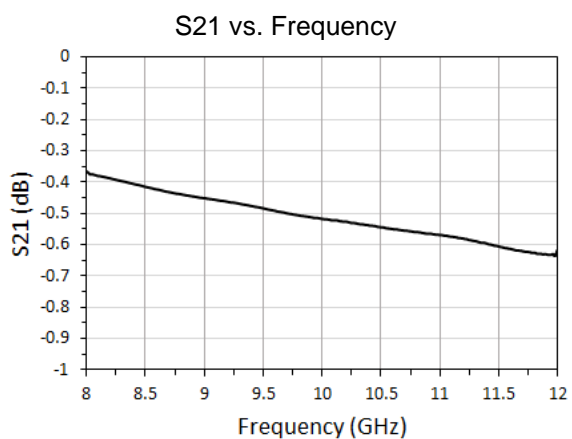
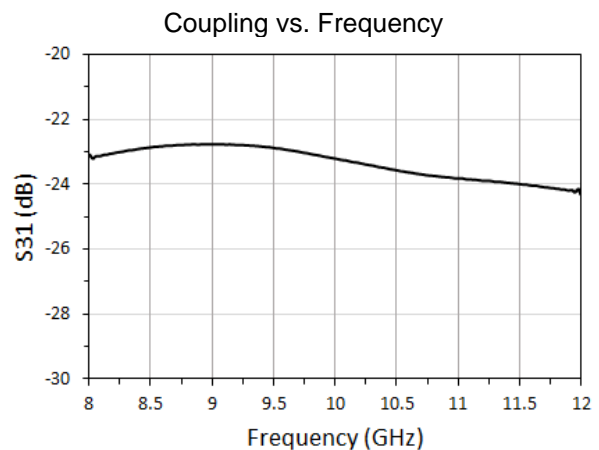
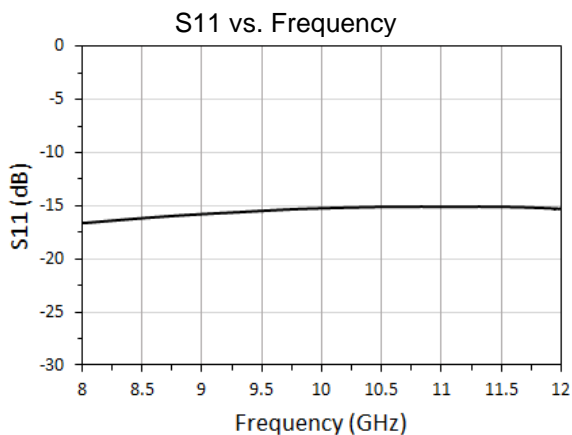

**GaAs Monolithic Microwave Integrated Circuit
X-Band Directional Coupler**

Size

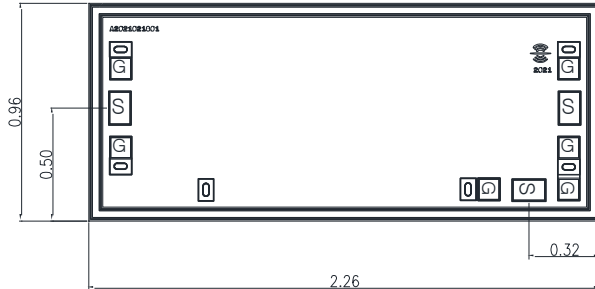

Remarks: Unit : mm, Tolerance : ±0.05mm

1. Chip bottom is gold plated and grounded.
2. Bonding pressure points are gold plated, pressure points sizes are 0.15x0.10mm.
3. Don't bond on the through holes.

Applications

1. Assembly and Bonding Diagram.

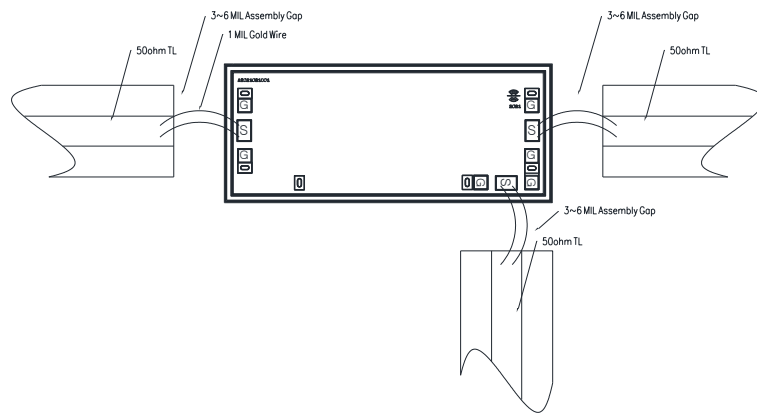

Assembly Diagram

2. Bonding Diagram.

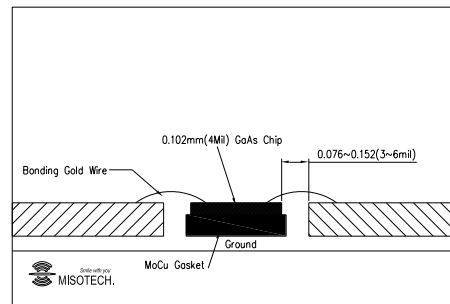
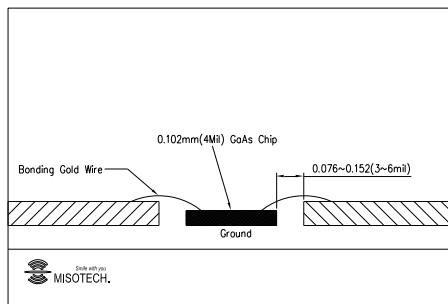

Note: Microstrip substrates should be located as close to the die as possible in order to minimize bond wire length. Typical die-to-substrate spacing is 0.076mm to 0.152 mm (3 to 6 mils)

Handling Precautions

Follow these precautions to avoid permanent damage.

Storage - All bare die are placed in either Waffle or Gel based ESD protective containers, and then sealed in an ESD protective bag for shipment. Once the sealed ESD protective bag has been opened, all die should be stored in a dry nitrogen environment.

Cleanliness - Handle the chips in a clean environment. DO NOT attempt to clean the chip using liquid cleaning systems.

Static Sensitivity - Follow ESD precautions to protect against ESD strikes.

Transients - Suppress instrument and bias supply transients while bias is applied. Use shielded signal and bias cables to minimize inductive pickup.

General Handling - Handle the chip along the edges with a vacuum collet or with a sharp pair of bent tweezers. The surface of the chip may have fragile air bridges and should not be touched with vacuum collet, tweezers, or fingers.

Mounting - The chip is back-metalized and can be die mounted with AuSn eutectic preforms or with electrically conductive epoxy. The mounting surface should be clean and flat.

Wire Bonding - Ball or wedge bond with 0.025mm (1 mil) diameter pure gold wire. Thermosonic wirebonding with a nominal stage temperature of 150 °C and a ball bonding force of 40 to 50 grams or wedge bonding force of 18 to 22 grams is recommended. Use the minimum level of ultrasonic energy to achieve reliable wirebonds. Wirebonds should be started on the chip and terminated on the package or substrate. All bonds should be as short as possible <0.31mm (12 mils).

Model Code

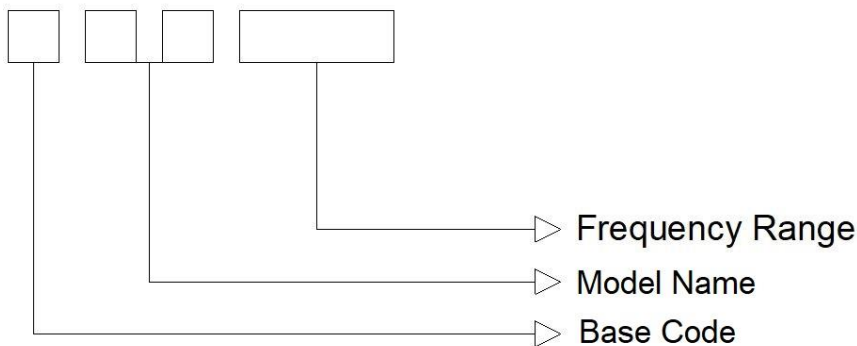

Remark

1. Basic Code (`M` M is an abbreviation of MISO)
2. Model Name (ex. `Coupler` abbreviation is a CU)
3. Frequency Range (included frequency information)